

Алматы (7273)495-231
Ангарск (3955)60-70-56
Архангельск (8182)63-90-72
Астрахань (8512)99-46-04
Барнаул (3852)73-04-60
Белгород (4722)40-23-64
Благовещенск (4162)22-76-07
Брянск (4832)59-03-52
Владивосток (423)249-28-31
Владикавказ (8672)28-90-48
Владимир (4922)49-43-18
Волгоград (844)278-03-48
Вологда (8172)26-41-59
Воронеж (473)204-51-73
Екатеринбург (343)384-55-89
Иваново (4932)77-34-06

Ижевск (3412)26-03-58
Иркутск (395)279-98-46
Казань (843)206-01-48
Калининград (4012)72-03-81
Калуга (4842)92-23-67
Кемерово (3842)65-04-62
Киров (8332)68-02-04
Коломна (4966)23-41-49
Кострома (4942)77-07-48
Краснодар (861)203-40-90
Красноярск (391)204-63-61
Курган (3522)50-90-47
Курск (4712)77-13-04
Липецк (4742)52-20-81
Магнитогорск (3519)55-03-13

Москва (495)268-04-70
Мурманск (8152)59-64-93
Набережные Челны (8552)20-53-41
Нижний Новгород (831)429-08-12
Новокузнецк (3843)20-46-81
Новосибирск (383)227-86-73
Ноябрьск (3496)41-32-12
Омск (3812)21-46-40
Орел (4862)44-53-42
Оренбург (3532)37-68-04
Пенза (8412)22-31-16
Пермь (342)205-81-47
Петрозаводск (8142)55-98-37
Псков (8112)59-10-37

Ростов-на-Дону (863)308-18-15
Рязань (4912)46-61-64
Самара (846)206-03-16
Санкт-Петербург (812)309-46-40
Саранск (8342)22-96-24
Саратов (845)249-38-78
Севастополь (8692)22-31-93
Симферополь (3652)67-13-56
Смоленск (4812)29-41-54
Сочи (862)225-72-31
Ставрополь (8652)20-65-13
Сургут (3462)77-98-35
Сыктывкар (8212)25-95-17
Тамбов (4752)50-40-97

Тверь (4822)63-31-35
Тольятти (8482)63-91-07
Томск (3822)98-41-53
Тула (4872)33-79-87
Тюмень (3452)66-21-18
Улан-Удэ (3012)59-97-51
Ульяновск (8422)24-23-59
Уфа (347)229-48-12
Хабаровск (4212)92-98-04
Чебоксары (8352)28-53-07
Челябинск (351)202-03-61
Череповец (8202)49-02-64
Чита (3022)38-34-83
Якутск (4112)23-90-97
Ярославль (4852)69-52-93

Россия +7(495)268-04-70

Казахстан +7(7172)727-132

Киргизия +996(312)96-26-47

akm@nt-rt.ru || <https://ametek.nt-rt.ru/>

Exhaust Gas Thermocouples

372A2221

Product Features and Benefits

- Superior quality
- Hermetically sealed for high accuracy and long life
- Simple quick installation saves time
- Talented technical support
- Parts are usually in stock to provide quick turn around time

AMETEK
POWER INSTRUMENTS

Hermetically designed exhaust gas thermocouple has been fully tested to OEM specifications. This 100% hermetic thermocouple also has the latest more compatible materials to help eliminate open circuits during start up, thus eliminating false turbine trips and inconvenient and expensive down times. Our new exhaust gas thermocouple has been subjected to rigorous qualification tests including vibration testing to 10 million cycles of simulated on turbine operation, thermal cycling the measuring tip 20,000 times between 1220°F and room temperature, and thermal cycling the hermetic terminal head 600 times between 700°F and -65°F, passing all OEM qualification tests and meeting all design specifications required by the OEM. Our unit is manufactured with an all welded construction that is superior to brazing in prolonging the life of the thermocouple. This thermocouple is a direct replacement for all other exhaust gas thermocouples on Frame turbines, whether you are replacing or upgrading your equipment.

Superior Quality

These type K ungrounded thermocouples are manufactured using conductor materials meeting special limits of error ($\pm 0.4\%$ accuracy), and have a time response of 2.9 seconds. All specification qualified exhaust gas thermocouples are manufactured per ASTM standards utilizing the highest purity insulation materials yielding superior insulation resistance at elevated temperatures. Thermocouples are manufactured and tested at various points during the manufacturing cycle to give you the highest possible level of quality. The testing includes helium leak testing of sealing points, calibration, thermal shock and insulation resistance.

Precise Installation

Exhaust gas thermocouples are designed to ensure proper installation every time. The bushing at the sensing end of the thermocouple seats firmly into the radiation shield allowing the junction to be in the proper position, giving you the optimum response time and accurate temperature measurement. The bushing is also fabricated of materials that reduces the possibility of seizure in the radiation shield. The cold end features a ceramic filled connector housing with a two pin hermetic sealed connector. The individual connector pins are made of KN and KP materials. This allows a homogeneous temperature measurement when applying the mating cables.

Technical Sales Support

Whether you are upgrading or replacing your exhaust thermocouples, Technical Team can help you solve your problems. We can help you upgrade from using the one piece design such as the 302A4010Pxxx or 351A3488Pxxx or if you just need to replace a 372A2221 exhaust gas thermocouple. Call our inside Sales Team at (716) 684-4501 ext. 291 and you'll get the support you need to make the right choices.

Dimensional Features

Hermetic Exhaust Gas Thermocouple Model 372A2221

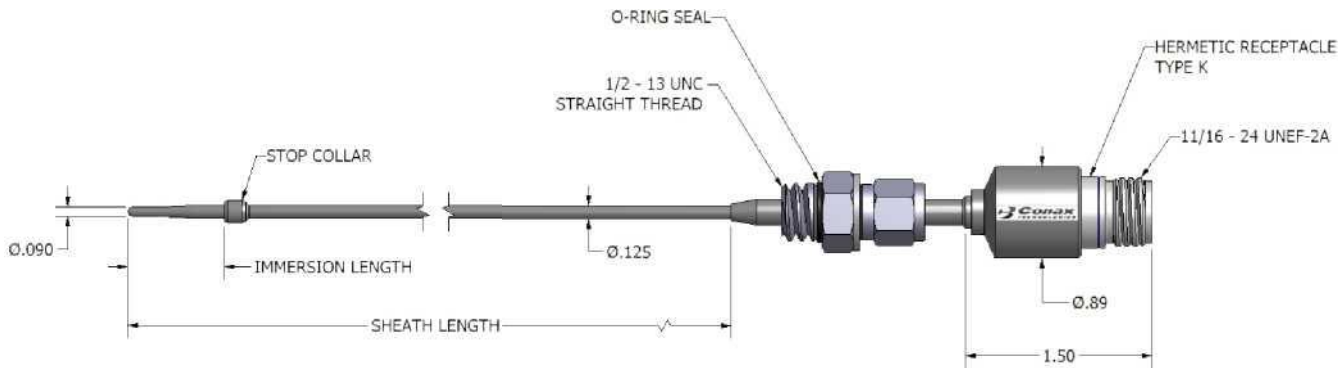

Specifications

Calibration

- Type K, KN/KP
- $\pm 0.4\%$ accuracy (special limits of error)
- Meets the requirements of ASTM E585 and ASTM E608

Insulation Resistance:

- 1×10^9 ohms @ 500 VDC

Time Response:

- 2.9 seconds

Hermetic Seal:

- 1×10^{-6} scc/sec He for the entire thermocouple

Sheath Diameter:

- 0.125" with reduced tip to .090 Diameter

Environmental Ranges:

- -20° to 700°F (-29° to 371°C) at the termination
- -20° to 392°F (-29° to 200°C) for the cable
- 100% humidity for the entire thermocouple

Applications:

- Frame turbines

Related Products

- Hermetic Exhaust Gas Thermocouple - Model 351A3488
Bulletin 6052
- Hermetic Exhaust Gas Thermocouple - Model 362A1102
Bulletin 6054
- Hermetic Wheelspace Thermocouples - Model 361A2289
Bulletin 6053
- Miniature Bearing Sensors
Bulletin 6035A
- Bearing Sensor Wire Seals: Catalog 5001C
- RTDs/Thermocouples: Catalog 5005

Also Available

- Radiation shields - Model 362A1344Pxxx
- Mating connector cables - Model 362A3345Pxxx
- Mating cables - Model 361A2327Pxxx

AMETEK

POWER INSTRUMENTS

Алматы (7273)495-231
Ангарск (3955)60-70-56
Архангельск (8182)63-90-72
Астрахань (8512)99-46-04
Барнаул (3852)73-04-60
Белгород (4722)40-23-64
Благовещенск (4162)22-76-07
Брянск (4832)59-03-52
Владивосток (423)249-28-31
Владикавказ (8672)28-90-48
Владимир (4922)49-43-18
Волгоград (844)278-03-48
Вологда (8172)26-41-59
Воронеж (473)204-51-73
Екатеринбург (343)384-55-89
Иваново (4932)77-34-06

Ижевск (3412)26-03-58
Иркутск (395)279-98-46
Казань (843)206-01-48
Калининград (4012)72-03-81
Калуга (4842)92-23-67
Кемерово (3842)65-04-62
Киров (8332)68-02-04
Коломна (4966)23-41-49
Кострома (4942)77-07-48
Краснодар (861)203-40-90
Красноярск (391)204-63-61
Курган (3522)50-90-47
Курск (4712)77-13-04
Липецк (4742)52-20-81
Магнитогорск (3519)55-03-13

Россия +7(495)268-04-70

Москва (495)268-04-70
Мурманск (8152)59-64-93
Набережные Челны (8552)20-53-41
Нижний Новгород (831)429-08-12
Новокузнецк (3843)20-46-81
Новосибирск (383)227-86-73
Ноябрьск (3496)41-32-12
Омск (3812)21-46-40
Орел (4862)44-53-42
Оренбург (3532)37-68-04
Пенза (8412)22-31-16
Пермь (342)205-81-47
Петрозаводск (8142)55-98-37
Псков (8112)59-10-37

Казахстан +7(7172)727-132

Ростов-на-Дону (863)308-18-15
Рязань (4912)46-61-64
Самара (846)206-03-16
Санкт-Петербург (812)309-46-40
Саранск (8342)22-96-24
Саратов (845)249-38-78
Севастополь (8692)22-31-93
Симферополь (3652)67-13-56
Смоленск (4812)29-41-54
Сочи (862)225-72-31
Ставрополь (8652)20-65-13
Сургут (3462)77-98-35
Сыктывкар (812)25-95-17
Тамбов (4752)50-40-97

Киргизия +996(312)96-26-47

Тверь (4822)63-31-35
Тольятти (8482)63-91-07
Томск (3822)98-41-53
Тула (4872)33-79-87
Тюмень (3452)66-21-18
Улан-Удэ (3012)59-97-51
Ульяновск (8422)24-23-59
Уфа (347)229-48-12
Хабаровск (4212)92-98-04
Чебоксары (8352)28-53-07
Челябинск (351)202-03-61
Череповец (8202)49-02-64
Чита (3022)38-34-83
Якутск (4112)23-90-97
Ярославль (4852)69-52-93